

Edelstahlkugelhähne, reduzierter Durchgang

Flansch / Flansch, DN 15-250

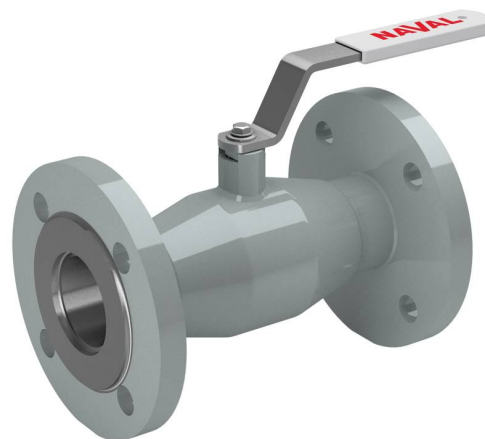

Gehäuse: Edelstahl, X2CrNiMo17-12-2 (1.4404)
 Kugel: Edelstahl, X2CrNiMo17-12-2 (1.4404)
 Spindel: Edelstahl, X2CrNiMo17-12-2 (1.4404)
 Spindeldichtungen: FPM/NBR
 Kugeldichtungen: PTFE+C
 Flansche: EN 1092-1
 Erhältlich PN 10, 16, 25, 40
 Länge: EN 558-1 (DIN 3202)
 Betätigung: DN 10-50 mit Griff aus Edelstahl.
 DN 65-250 mit Griff aus verzinktem Stahl.



Betriebsbedingungen

-30 °C - +200 °C
 Unter -10 °C Hersteller kontaktieren



Nicht für Dampf

DN 15 - 150

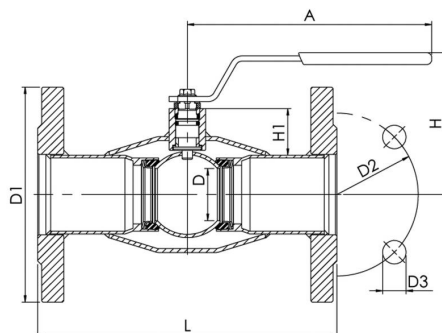

DN 200 - 250

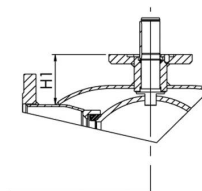

DN	PN	Produktnr.	A	D	D1	D2	D3	H	H1	L	Bohrungen	kg
15	40	286 553	145	10	95	65	14	99	21	130	4	1,9
20	40	286 555	145	15	105	75	14	103	22	150	4	2,7
25	40	286 556	145	20	115	85	14	113	28	160	4	3,4
32	40	286 557	145	25	140	100	18	116	27	180	4	5
40	40	286 558	188	32	150	110	18	112	34	200	4	6,1
50	40	286 559	188	40	165	125	18	118	34	230	4	8,5
65	16	286 560	278	50	185	145	18	148	51	270	8	10,5
80	16	286 561	278	65	200	160	18	160	58	280	8	12
100	16	286 562	278	80	220	180	18	171	54	300	8	15,5
125	16	286 563	400	100	250	210	18	220	68	325	8	21
150	16	286 564	600	125	285	240	22	240	74	350	8	25
200	16	286 566	870	150	340	295	22	281	92	400	12	50
250	16	286 567	1200	200	405	355	26	343	108	550	12	90